

Schaffhausen, 27 September 2022

Welcome to Capital Markets Day 2022

Andreas Müller, CEO

+ Executive Committee



Andreas Müller
CEO

Member of the Executive Committee since 2017, CEO since 2019



Mads Joergensen
CFO

Member of the Executive Committee since 2019



Joost Geginat
President
GF Piping Systems

Member of the Executive Committee since 2016



Carlos Vasto
President
GF Casting Solutions

Member of the Executive Committee since 2018



Ivan Filisetti
President
GF Machining Solutions

Member of the Executive Committee since 2020





IR and Communication contacts



Daniel Bösiger
Head IR / Risk
Management



Beat Römer
Head Corporate
Communications





Program today

Introduction	9:30 to 9:50
First show case presentation	10:00 to 10:45
Break or sustainability booth	
Second show case presentation	11:00 to 11:45
Break or sustainability booth	
Third show case presentation	12:00 to 12:45
Break or sustainability booth	
Q&A session in meeting room	13:00 to 13:30
Lunch	13:30 to 14:30
Plant tour – two groups registered	14:30 to 15:15



Innovative solutions for tomorrow

+ Global trends ...

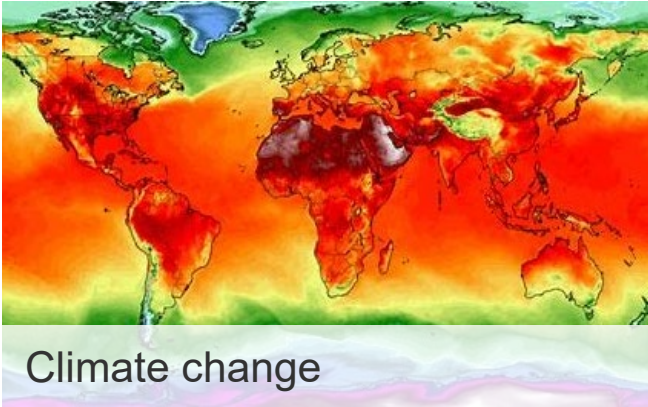

... offer great opportunities



Hydrogen / Battery / e-mobility



Water treatment

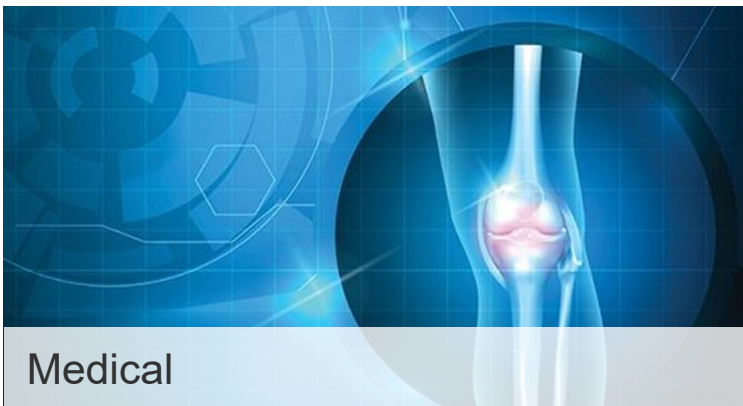

Medical

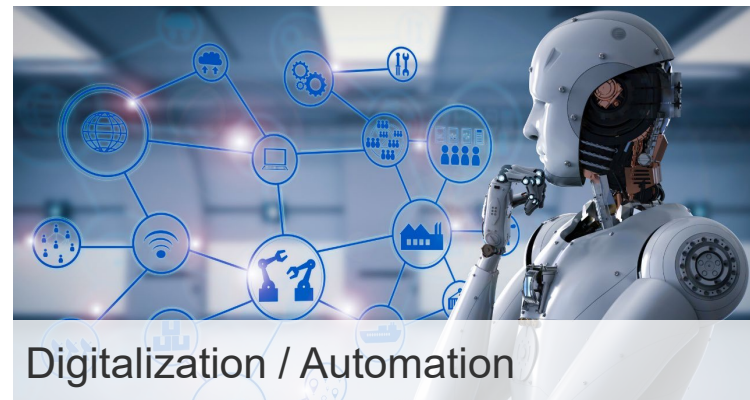

Digitalization / Automation



Our Vision

GF is a **sustainability** and **innovation** leader
providing superior
customer value





Our sustainability commitment ...



Product Portfolio

Innovate products and solutions for a sustainable lifecycle



Product portfolio
70% of sales with social or environmental benefits



Climate & Resources

Decouple resource consumption from growth



CO₂e emissions
Reduce absolute CO₂e footprint by 21%



Water
Reduce water intensity by 20% in high stress areas



Waste
Reduce waste intensity by 20% sent to landfill or incineration



Supply chain
Perform sustainability assessments for 80% of procurement spend



People & Well-being

Pursue a diverse, engaging and safe work place



Diversity and inclusion
25% of newly appointed managers are female



Employee engagement
At least 80% recommend GF as an employer of choice





Health and safety
Reduce accident rate by 30%

100%
of new products
w/ sustainability contribution



... recognized by investors' community



MSCI ESG RESEARCH LLC
MSCI 

▶ AA



SUSTAINALYTICS

▶ 79 out of 512
(15th percentile)



ISS ESG 

▶ C+



CDP
DISCLOSURE INSIGHT ACTION

▶ A- on Climate
A- on Water



WSJ
100
MOST SUSTAINABLY MANAGED COMPANIES 2020

GF is rated as number 9 most sustainably managed companies 2020 by WSJ
^{*)} out of 5'500 companies



GF is member of SXI Switzerland Sustainability 25[®] since 2014



Have a look at our "Sustainability booth" outside

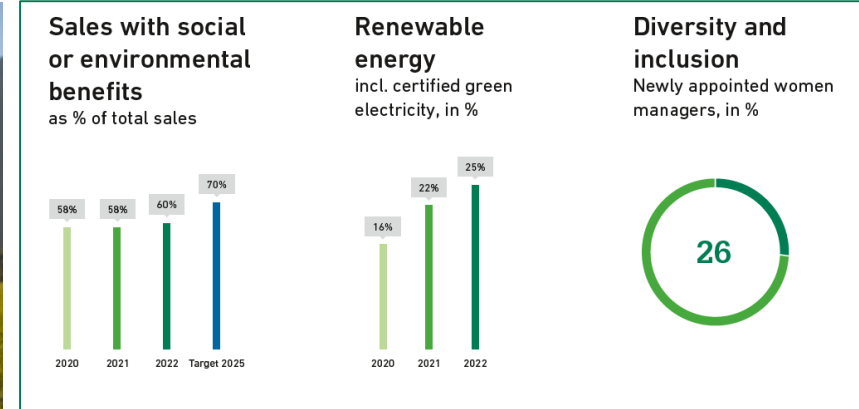

Our GF Sustainability Managers



Lindsay Zingg
Corporation



Anna Oetinger
Corporation



Dominik Scherer
GF Piping Systems



Christina Widmann
GF Casting Solutions



Mark Posey
GF Machining Solutions



Our Strategy 2025 has a strong focus on innovation ...

Drive profitable growth

through intelligent and sustainable solutions

Increase robustness

through resilient portfolio and operational excellence

Evolve culture

towards more performance and learning

CHF 4.4 – 5.0 bn

Sales
including acquisitions

9 – 11%

Return on sales (ROS)

20 – 22%

Return on invested capital (ROIC)





... with our global R&D resources ...

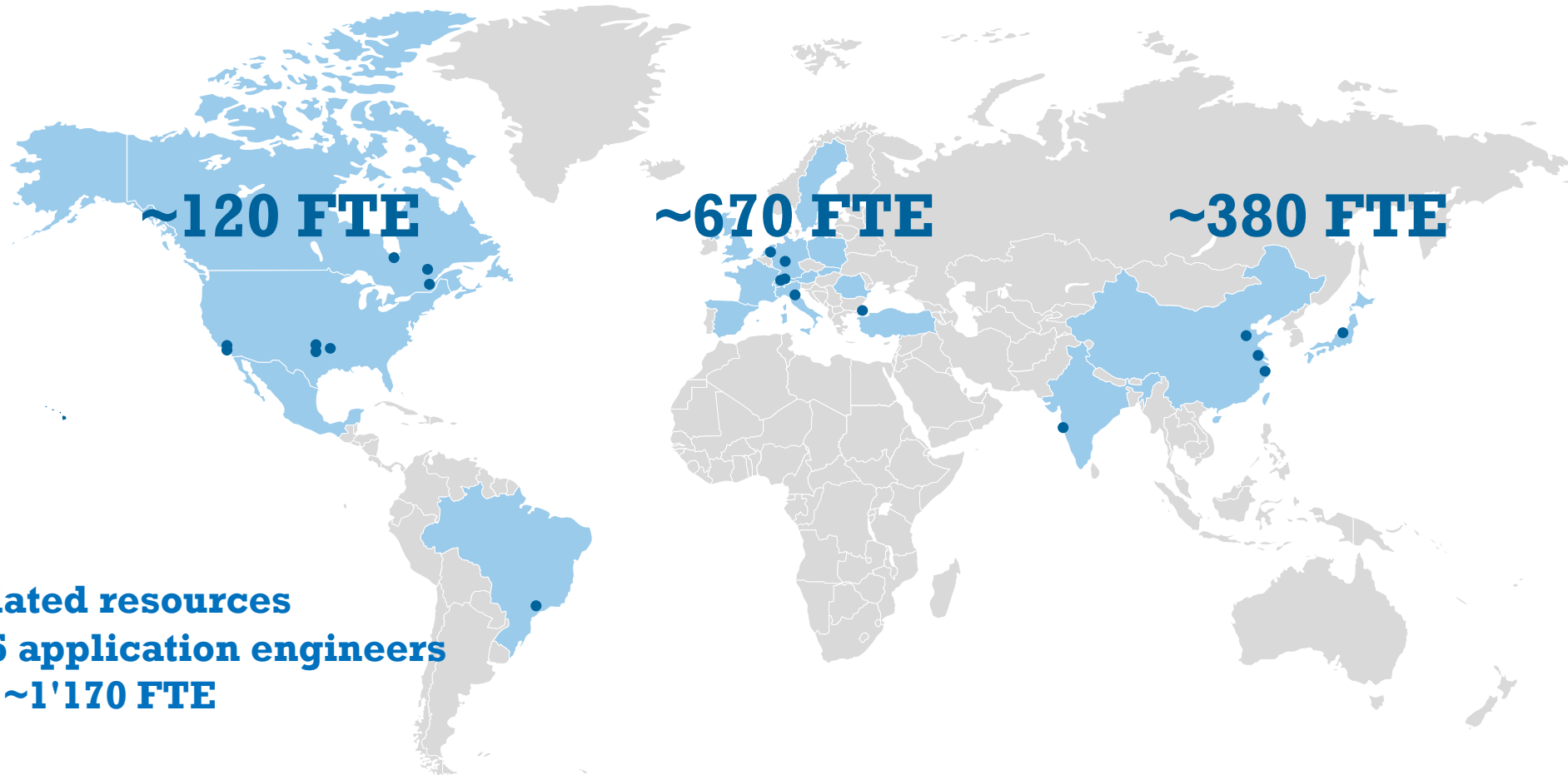

**R&D related resources
incl. 205 application engineers
Overall ~1'170 FTE**



... accelerated through a broadened eco-system

Innovation Eco-system being expanded

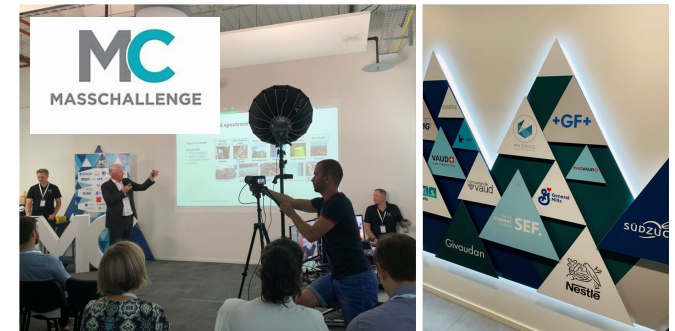
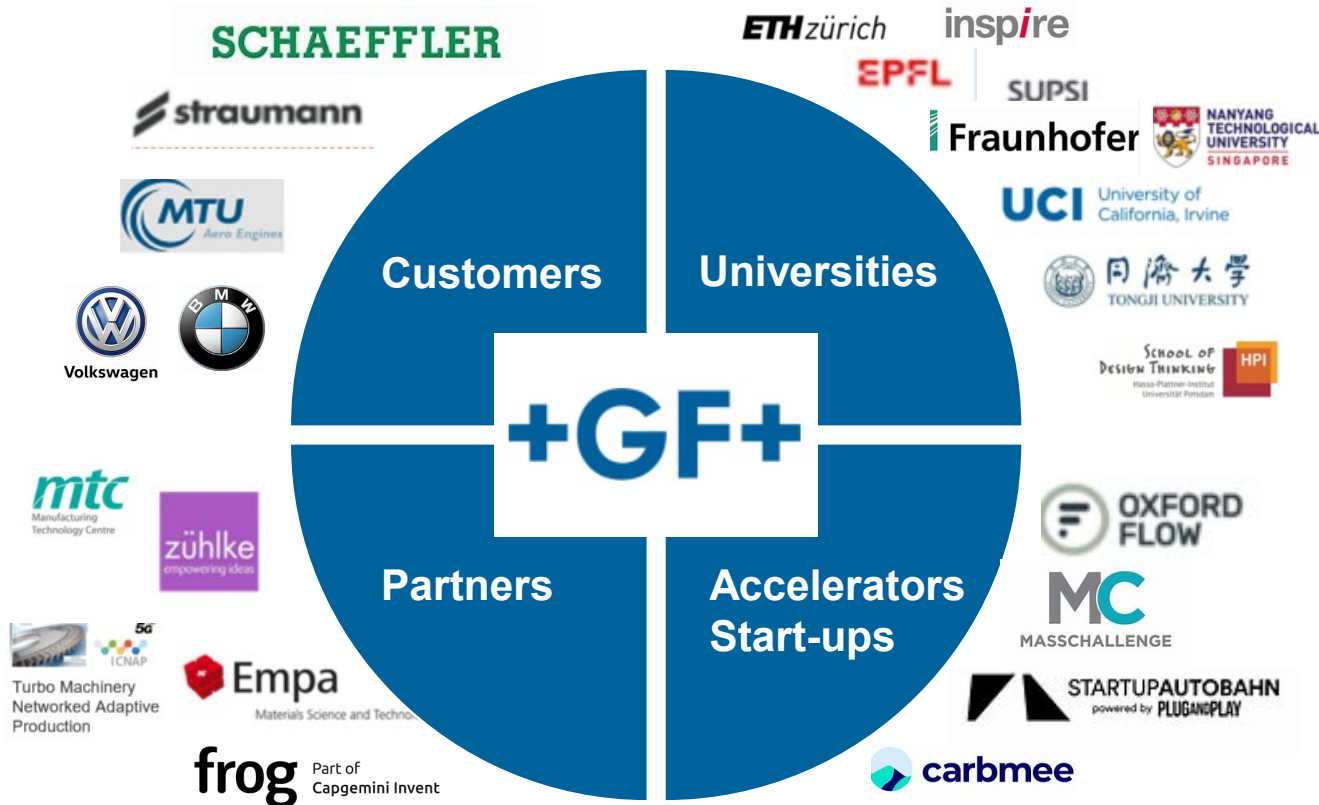

A hand is shown holding a globe. The globe is surrounded by various white line-art icons representing different aspects of sustainability and innovation, such as wind turbines, solar panels, buildings, leaves, a bicycle, and a person. The background is a soft-focus green and blue bokeh.

Innovative solutions for tomorrow



Capital Markets Day 2022 – show cases

Water as a service



Big castings / e-mobility

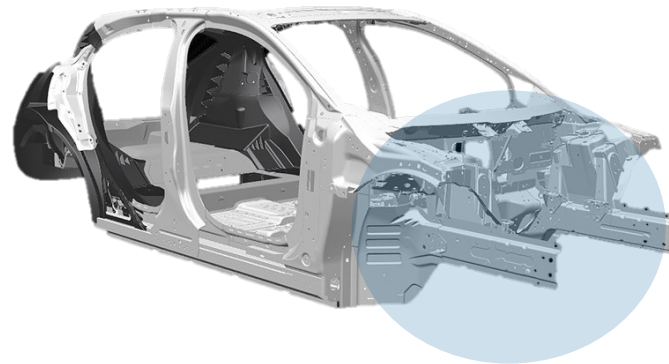

Factory of the future

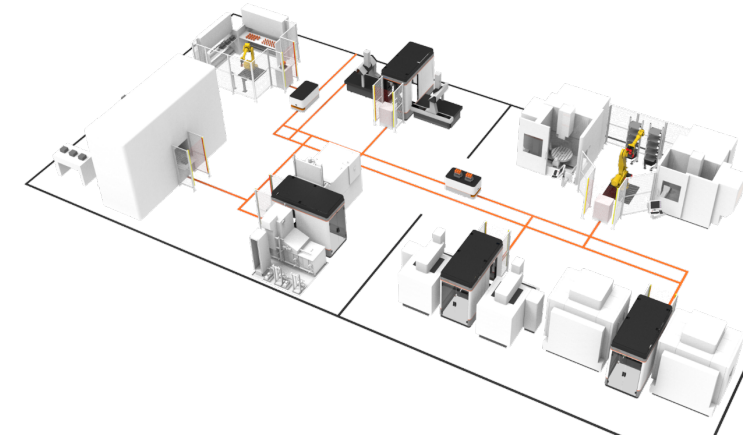



Our purpose

**Becoming better
every day – since 1802**



How to split into groups



Three groups – please follow your guides

Group A – Cesar Sayegh

+GF+

Name

Zeile 1

Zeile 2

A

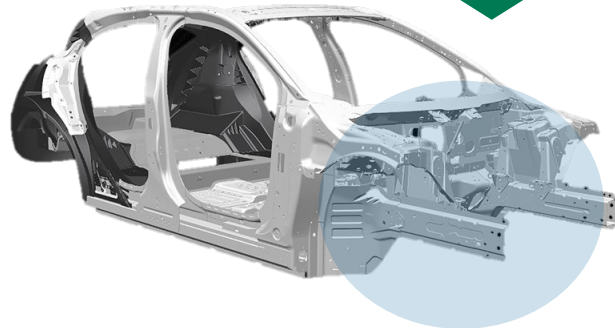

Group B – Thomas Müller

+GF+

Name

Zeile 1

Zeile 2

B

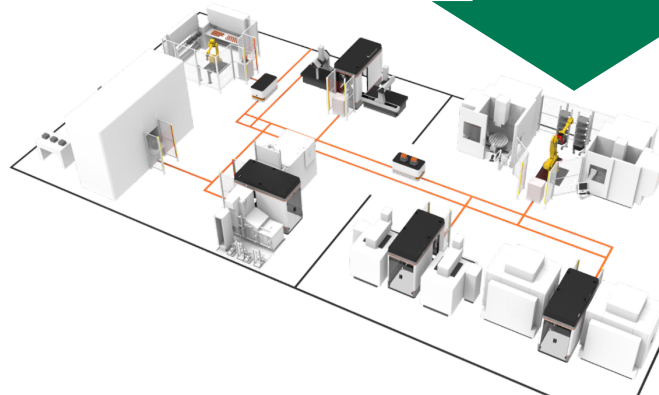

Group C – Oliver Abderhalden

+GF+

Name

Zeile 1

Zeile 2

C

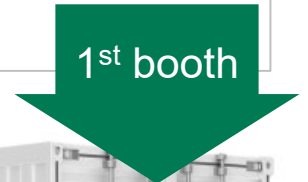



How to use the earphones

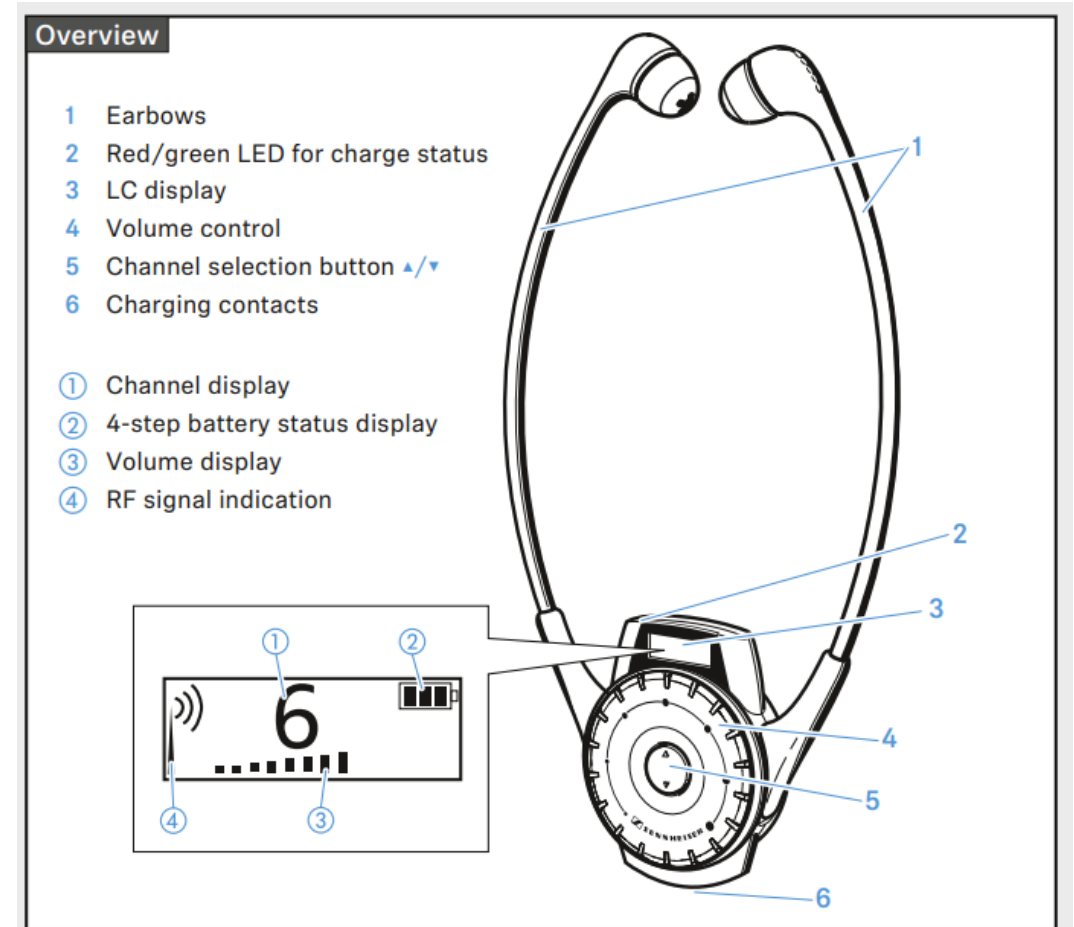
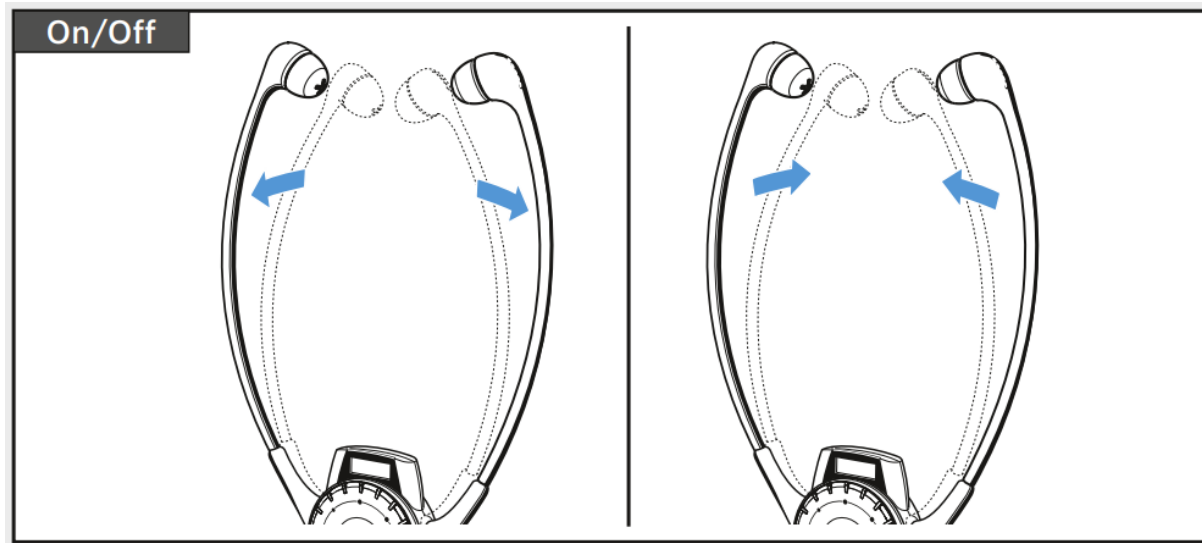



Some remarks

- You may **leave your belongings in this room** until the Q&A session
- **Please do NOT make photographs** – you may download the documentation (QR code)
- We will, however, make **pictures** – be aware that **these will be published** on our website!



Disclaimer

This document is for presentation purposes only and should not be construed as an offer, invitation or solicitation to subscribe for, purchase or sell any investment. Neither it nor anything it contains shall form the basis of any contract whatsoever.

Opinions expressed herein reflect the current judgement of the management of GF. The presentation contains forward-looking statements that involve risks and uncertainties. The actual results of GF may differ materially from those anticipated in these forward-looking statements and forecasts as a result of a number of factors.

The management of GF does not accept any liability whatsoever with respect to the use of this presentation.